

Price \$3.00

INSTRUCTION MANUAL FOR THE

# Galaxy 300

Section 1. Unpacking, Damage Claims.

- 1-1. Unpacking, Damage Claims.
- 1-2. Unpacking, Installation of parts packed separately.

Section 2. Installation.

- 2-1. Front and rear panel drawings.
- 2-2. Connection of power, antenna, microphone, key, external speaker.
- 2-3. Set-up adjustments.
- 2-4. Connection of accessories.
- 2-5. Connection to Linear Amplifiers.
- 2-6. Antenna considerations.
- 2-7. Mobile installation.

Section 3. Operation.

- 3-1. Fixed station operation.
- 3-2. Mobile operation.
- 3-3. Operation outside the normal tuning range.

Section 4. Theory of operation.

- 4-1. Controls and their functions.
- 4-2. General circuit analysis.
- 4-3. Power supplies, including clock adjustment.

**Section 5. Servicing, alignment, and trouble shooting.**

- 5-1. GALAXY 300 voltage, resistance, and physical layout charts.
- 5-2. PSA-300 and G-300DC voltage and resistance charts.
- 5-3. VX-1 voltage and resistance charts.
- 5-4. Trouble symptoms and probable cures.
- 5-5. Complete alignment of GALAXY 300.

**Section 6. Ordering replacement parts and returning units for factory service.**

- 6-1. Ordering parts for units in warranty.
- 6-2. Ordering parts for units out of warranty.
- 6-3. Returning units to factory for service.

**Section 7. Parts lists and schematics.**

- 7-1. GALAXY 300 schematic. See also large fold out.
- 7-2. VX-1 VOX schematic.
- 7-3. PSA-300 A. C. power supply schematic.
- 7-4. G-300DC power supply schematic.
- 7-5. GALAXY 300 parts and price list.
- 7-6. VX-1 parts and price list.
- 7-7. PSA-300 parts and price list.
- 7-8. G-300DC parts and price list.

**Section 8. Warranty.**

- 8-1. World Radio Laboratories Warranty on the GALAXY 300 and associated equipment.

## GALAXY MANUAL

### 1-1 UNPACKING:

Conspicuous signs indicating carrier damage responsibility--action to be taken in the event of obvious or hidden damage.

All shipments from WRL are packed by experienced personnel so that shipping damage can be held to a minimum. The carrier, upon receipt, assumes full responsibility for safe delivery. You must follow these instructions so that there will be no delay or loss of reimbursement for damaged goods.

1. When a shipment arrives with visible damage, carton open or broken, do not sign a receipt unless it clearly states that there is damage. Also, you must request that a joint inspection form be completed. This is an inspection for damages by you and a representative of the delivering agent.
  - (a) In the event the shipment comes Parcel Post, insured, report the damage to the Postmaster in your city. He will complete the necessary claim papers to be forwarded.
2. If there is no visible damage and you find the shipment damaged after opening, contact the carrier or your Postmaster promptly to have a joint inspection form completed.

UNDER NO CIRCUMSTANCES should you return the shipment to WRL WITHOUT a joint inspection report or before filing a claim. All wrapping should be saved. On Parcel Post shipments, you will find the insured number on the wrapper.

If you should refuse the shipment and send it back to WRL without the above having been done, it could nullify any claim being made because there is no proof as to when the damage occurred.

If you follow the foregoing procedures, any adjustments will be made sooner and claims will be paid faster.

If you do not follow the foregoing, adjustments will be difficult to make because, according to regulations, the responsibility for safe shipping rests with the carrier when he signs a receipt for the shipment.

1-2. Unpacking and installing parts packed separately. Remove all packing material carefully. Examine for any plugs, instructions, etc. It is recommended that the packing material be saved, when ever possible, for future shipping of the unit.

In The GALAXY 300 itself, there are several unpacking procedures to follow.

1. After removal from the carton, open the lid and remove the tape used to hold down all tubes during shipping.
2. Remove spare power plug taped to the chassis.
3. Remove the 6HF5 tubes, packed in the right side of the GALAXY, and insert carefully in their sockets. Handle gently.

4. Read and follow the installation and operation instructions in this manual before applying power or making any connections or adjustments! THIS IS IMPORTANT. IF ANY UNIT RETURNED FOR IN-WARRANTY REPAIR SHOWS EVIDENCE OF DAMAGE CAUSED BY MIS-HANDLING OR FLAGRANT DISREGARD OF INSTRUCTIONS, THE WARRANTY WILL BE VOID. In normal use, WRL warrants tubes and labor for 90 days, everything else for a full year from the date of purchase. (See Section 8). Keep that warranty in effect!

2-1 Front and rear panel drawings. See section 5-1 for tube and coil layout drawing. Note: The dial hairline calibration adjustment is located above the frequency dial. To adjust, loosen by turning knob counterclockwise 1/2 turn, set hairline to actual frequency, tighten knob gently.

FRONT PANEL (Figure A)

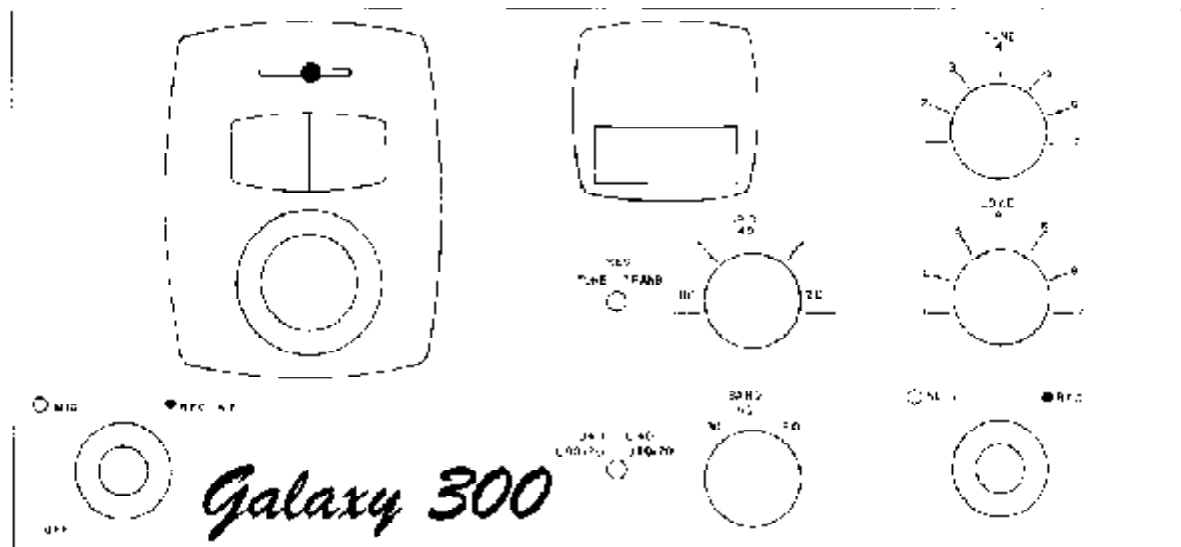

REAR PANEL (Figure B)

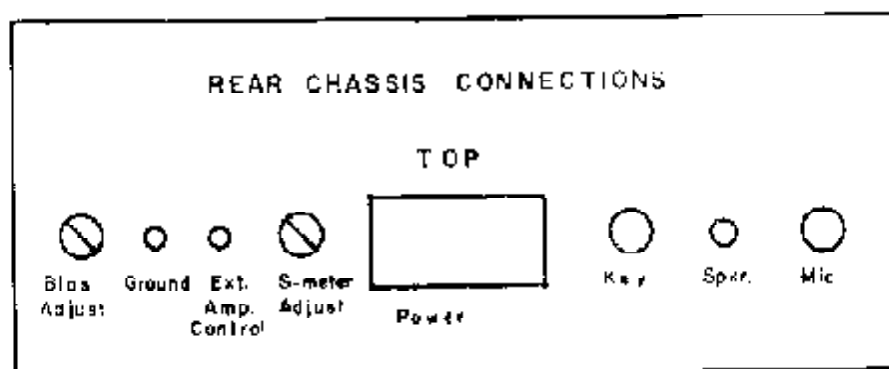
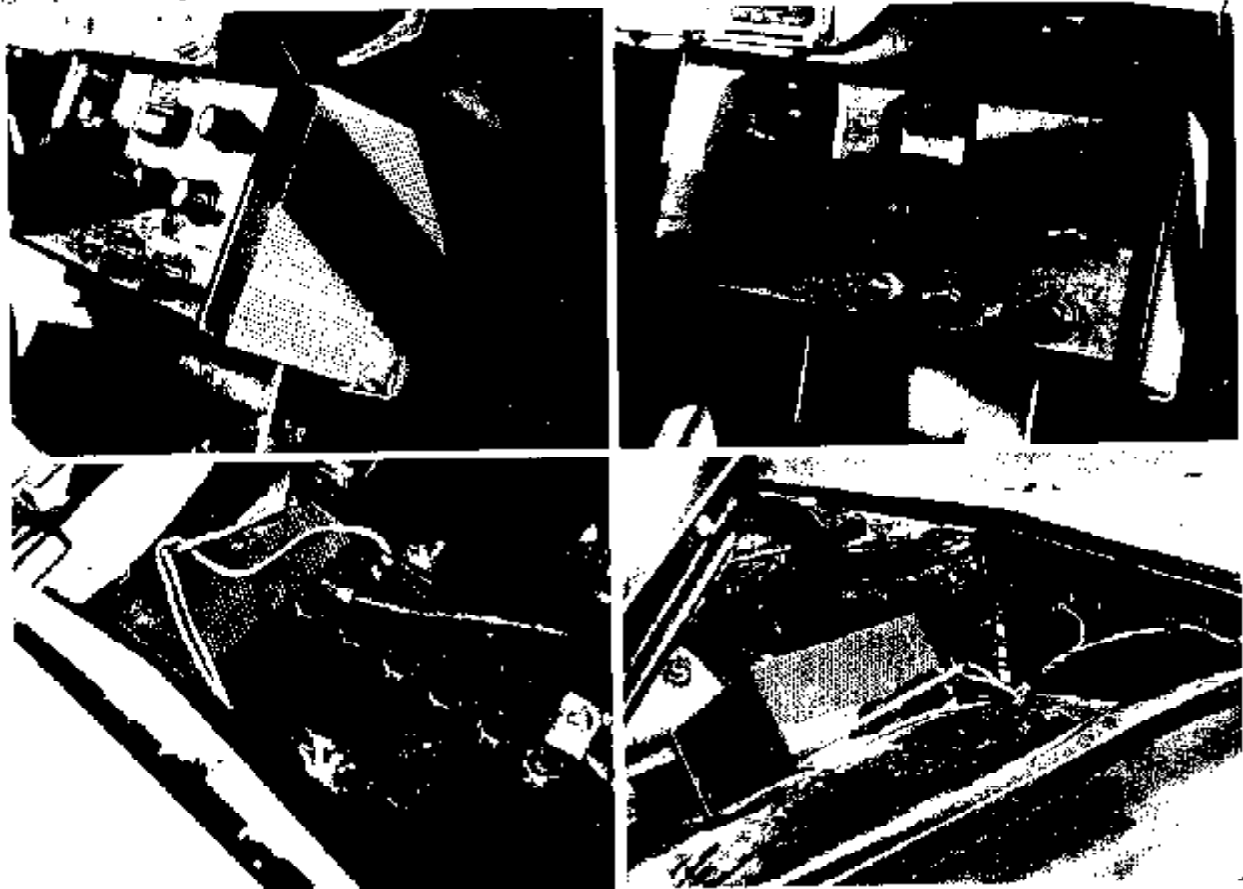

diagram of the Galaxy, section 7. Regulation of the 800 volt line should be 15% or better. A Jones S-312-CCT plug will mate with the Galaxy power plug.

Connection to the WRL G-300 DC power supply:--The G-300 DC power supply is suitable for use on 12 volt D. C. negative ground systems only. A Jones S-408CCT plug is provided with the G-300 DC for use on a cable. A Jones S-312CCT is supplied with the Galaxy. Belden #8448 is suitable for cable up to 10 feet. Use the black #18 wire paralleled with one of the #22 wires for the ground lead, and the red #18 wire paralleled with one of the #22 wires for the filament lead. It is desirable to keep this cable as short as possible, however, up to 10 ft. is permissible. For longer cable lengths it is necessary to make the filament and ground wires heavier than described above. A #18 should be paralleled with each for every additional 5 ft. of cable length over the 10' specified above.

The WRL MX-1 mount for the Galaxy (WRL #66D042--S. 4. 85) provides a suitable mounting for nearly every car. It is a stable--but not absolutely rigid mount. A very rigid mount causes vibration to reach the equipment and a semi-rigid mount is preferred.

FIGURE C. The GALAXY 300 and the G-300 DC mobile power supply photographed in typical mobile installations.



The battery leads should be #8 or heavier. (See your local electrical or Hardware dealer for suitable terminals to connect to your battery. Blackburn L70 lugs suggested). Use two #8 wires for the positive battery lead and one for the negative lead. Keep the battery leads as short as possible, no longer than 3 feet, as currents as high as 45 amperes will be flowing at peak drain.

Mount the G-300 DC where there is some air circulation. The firewall of an automobile is not good, as air flow is restricted. Forward in the engine compartment near the battery is preferred. Mount on a flat surface or make a good solid bracket which can be bolted to the car. Use 1/4 inch bolts and lockwashers. This aids the ground connection, as well as making loss of the unit due to bolts vibrating loose less likely.

Cable connections are shown in the table below.

G300DC S-408CCT	Galaxy S-312CCT
Pin #1---#8 wire to battery positive	-
Pin #2---#8 wire to battery positive	-
Pin #3-----#22 wire-----	Pin #9, -95 volt bias
Pin #4-----#22 wire-----	Pin #3, +325 volt low B+
Pin #5-----#22 wire-----	Pin #1, 4800 volt high B+
Pin #6-----#22 wire-----	Pin #4 primary relay
Pin #7-----#8 wire to battery negative-----	ground
Pin #7-----#18 & #22 wire-----	Pin #10 & 11 (jumper 10 to 11) ground
Pin #8-----#18 & #22 wire-----	Pin #8 filament
external loudspeaker-----	Pin #6--Jumper to Pin #5--P. T. T. relay to Pins 10 & 12 or to jack on rear.

With the connections given in the preceding paragraph, the switch on the REC. A. F. control will turn off and on all filaments and high voltages and serve as a master on-off control (for DC operation only). When the REC. A. F. control is turned clockwise from the OFF position, the switch actuates the relay in the G-300 DC unit, applying all filament and high voltage to the Galaxy. Allow at least one minute warm up in the RECEIVE position, as the 6HF5's in the final amplifier are slow heating tubes, and may be damaged if drive and screen voltage are applied before they are up to temperature. See Section 3-2 for details of operation.

#### 2-3 Set up adjustments:

**WARNING: THE GALAXY 300 MUST BE CONNECTED TO A 50 OHM LOW SWR ANTENNA OR A 50 OHM DUMMY ANTENNA OF SUFFICIENT POWER RATING WHEN MAKING ANY TRANSMITTER ADJUSTMENTS, OR SEVERE DAMAGE MAY RESULT.**

Connect a suitable antenna or dummy (Heathkit Antenna is satisfactory) to the SO-233 connector on the rear panel. Connect the power supply, PSA-300 or G-300DC. Set the TUNE-REC-TRANS switch to REC. Turn on the power supply. Allow one minute warm-up.

Set the **BAND** switch to the band in use. Advance the **REC. H.F.** control fully clockwise. Advance **REC. A.F.** control about 1/2 on. Adjust **S-meter** zero set (rear panel center control) for zero on the **S-meter**. If an antenna rather than a dummy is connected, temporarily remove while setting the **S-meter** zero.

Set the **LOAD** control at "1" for 80 meter operation, "2" for 40 meter operation, and "4" for 20 meter operation. Adjust the **TUNE** control for loudest received signals; approximately "6" on 80 meters, "5" on 40 meters, and "3" on 20 meters. Set **GRID** control to band in use.

Set the **BIAS** control on the rear of the chassis fully counter-clockwise. Set the **TUNE-REC-TRANS** switch to **TRANS** and then quickly adjust the **NULL** control for minimum reading. Set the bias control (rear of chassis) for a meter reading of 80 milliamperes, or "S-2" on the lower meter scale. Carefully re-adjust the **NULL** control for lowest possible meter reading. If the meter drops below "S-2", re-set **BIAS** for an "S-2" reading. **IN THE ABOVE STEP, DO NOT LET THE METER READING STAY ABOVE "S-2" FOR MORE THAN 30 SECONDS, OR THE FINAL TUBES MAY BE DAMAGED.**

2-4 Connection of accessories.

Installing the **VX-1 VOX** unit. TURN OFF POWER SUPPLY. Open cabinet lid. Using plastic handle long screwdriver, short both caps of the final tubes to ground to be sure all capacitors are discharged. Remove local plug at left rear of chassis and plug in **VX-1 VOX** unit. Turn on power supply and allow one minute warmup. Plug in microphone.

Turn **ANTI-VOX** control fully clockwise, **HOLD TIME** about mid-range. While close-talking into mike in normal voice, advance **VOX GAIN** control clockwise until relay pulls in reliably. Adjust **HOLD TIME** to your personal requirements. It may be necessary to back down **ANTI-VOX** with some voices. **VOX** adjustments are to be made with transmitter. "**MIC**" (mike gain) at minimum.

**NOTE!** Many microphones which have P.T.T. also short out the microphone element when the mike switch is in the **OFF** position. When using **VOX**, simply leave the mike switch in the **ON** position.

**External speaker.** Plug a 3 to 8 ohm speaker into the external speaker jack on the rear panel. On serial numbers above #3300A, this will silence the internal speaker in the **PSA-300** power supply. A silencing type jack is available (Part #100-3, --.45¢) for earlier units and will fit the same mounting holes.

4 to 3,000 ohm earphones may also be plugged into the internal speaker jack.

**NOTE: Do not** install a PM speaker inside the Galaxy cover. It may cause poor carrier suppression due to magnetic field. A straight or semi-automatic key can be plugged into the key jack on the rear panel using a standard 1/4 inch diameter sleeve two wire plug, (World Radio #1D025, --.48¢).

An **SWR** bridge is a highly recommended accessory, as an antenna with **SWR** above 2:1 may cause damage to the Galaxy. The **Cosco Reflectometer CM52**



(World Radio #66D006, \$29.95) is most satisfactory. It should be connected between the antenna and the Galaxy SO-236 output jack, J1.

In measuring the SWR of an antenna, tune up as described in section 3-1 (fixed operation) or 3-2 (mobile), injecting only enough carrier to read the SWR meter. Keep the NULL control near the minimum point, and the plate current under 150 milliamperes (1.5 on the top scale) to prevent possible damage to the final amplifier if the antenna should have a high standing wave ratio.

Phone patch operation. The Galaxy has been used successfully with a number of phone patches. Among the most successful is the Waters "Universal Hybrid Coupler", Model 3001, (World Radio #80D036, \$49.95). The Waters manual Fig. 7, describing installation with a Collins KWM-1 with push-to-talk, can be used as a guide for proper connection to the Galaxy. The only unusual point to note is the necessity of carrying the push-to-talk lead (tip of mike plug) around the patch via an adaptor cable. Receiver audio output is available at Pin 12 of the power plug of the Galaxy and pin 16 (ground). The Galaxy mike jack is wired for ground on sleeve, audio on ring, push-to-talk on tip.

## 2-5 Using the Galaxy with a linear amplifier.

The Galaxy can be used with any linear amplifier requiring 75 to 200 watts PEP drive. This includes most grounded grid or "passive grid" amplifiers. It is necessary to provide a relay system to switch the antenna to the Galaxy during receive and to the linear during transmit, and at the same time connect the Galaxy output to the linear input during transmit. This relay can be controlled by the "external control" jack, (J4) on the Galaxy. The relay must be set up so that grounding the center pin of J4 will actuate the relay. A suitable system using a DPDT relay is shown below. NOTE: Do not use over 28VAC/DC on (J4) of the Galaxy.

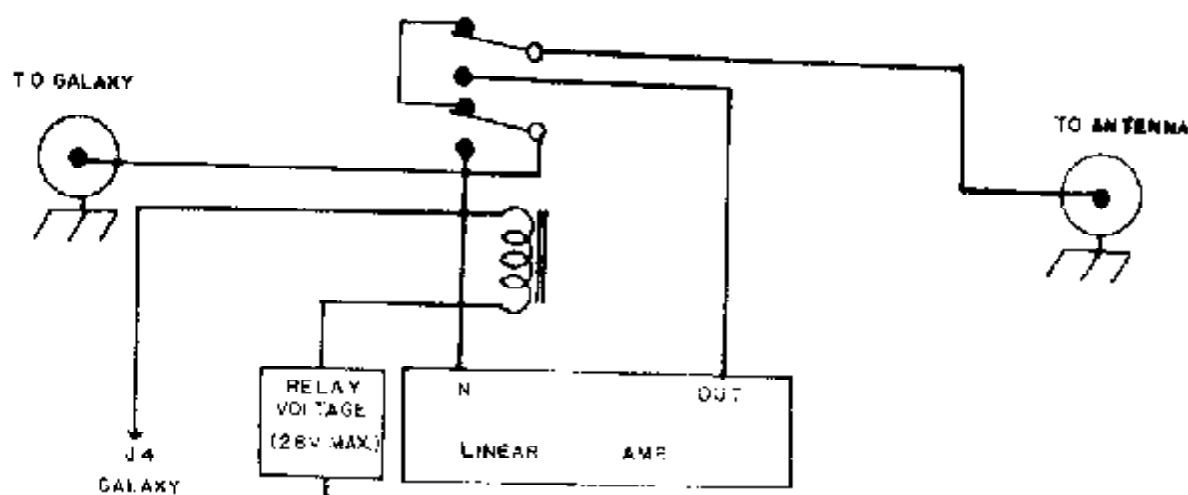

Fig. D. Relay system for use with Linear Amplifier

## 2-6 Antenna considerations.

IT IS ABSOLUTELY IMPERATIVE THAT AN ANTENNA WITH S. W. R. OF 2:1 OR LOWER BE USED WITH THE GALAXY 300. IF THE STANDING WAVE RATIO OF THE ANTENNA IS HIGHER THAN 2:1, DAMAGE TO THE GALAXY FINAL TUBES, COILS, CAPACITORS, AND OTHER COMPONENTS MAY RESULT, AND WILL NOT BE COVERED BY WARRANTY.

It is strongly recommended that the Galaxy installation include one of the many available good SWR Meters which can be left in the antenna feedline at all times, and which will show any change in the antenna SWR due to damage to the antenna or feedline. We recommend the Cosco Reflectometer, Model CM52 (WRL #86D006, --\$29.95) as being one of the good units now on the market.

Measure the SWR of YOUR antenna before running the Galaxy 300 at full power. This can be done safely even with high-SWR antenna, simply by doing all the Galaxy tune-up in the TRANS position, rather than the TUNE position, and keeping the NULL control set so that the plate current never rises above 1-1/2 on the top scale of the Galaxy meter. This holds the power down to a maximum of 120 watts input and protects the final amplifiers. If the SWR meter is set for maximum sensitivity, this will provide ample power to operate the SWR meter. In other words, inject only enough carrier to operate the SWR meter.

Place Galaxy panel switch on TRANS, and adjust GRID control for maximum meter indication. If meter indicates over 150 MA, Quickly adjust NULL control to hold meter reading at about 150 MA. Set final LOAD at "U" on knob scale and adjust final TUNE for dip. Do not exceed 30 seconds for this sequence of adjustments.

Adjust SWR Bridge per manufacturer's instructions to read actual antenna SWR. If over 2:1 corrective action must be taken at the antenna to secure a lower SWR.

2-7 The twin secrets of a good mobile operation are: Proper installation of the power supply, and proper installation and tuning of the antenna. For maximum signal, the antenna should be of the longest possible length, with a low-loss high-Q loading coil, mounted fairly high on the car body, and carefully tuned to exact resonance. The addition of a matching network at the feedpoint is of some help, and at times is necessary to get the SWR below 2:1. Top capacitive loading will decrease the amount of coil necessary and raise the efficiency of the antenna by reducing coil losses.

By all means USE AN SWR BRIDGE IN TUNING THE MOBILE ANTENNA FOR A LESS THAN 2:1 STANDING WAVE RATIO. See section 2-6 for a tune-up method which will prevent damage to the transmitter while making the SWR measurements. The various antenna manufacturers include installation and tuning procedures with their antenna. READ AND FOLLOW THEIR INSTRUCTIONS--AND CHECK THE RESULTS WITH A STANDING WAVE RATIO METER. A GOOD MATCH AND PROPER TUNING IS A MUST FOR GOOD MOBILE OPERATION. We recommend the Cosco Reflectometer Model CM52 SWR meter

(WRL #85DC06, --\$29.95).

See the various mobile handbooks for other tips, such as: Filtering regulator noise, bonding of car, spark plug noise suppression, etc. Normally, your own car will be the worst offender and noise from passing cars will only be momentary.

A speaker will be required. WRL offers a 4" speaker in a wood case (WRL #88D059, --\$2.99) or you can use any 3 to 8 ohm PM speaker. The car radio speaker is often used and normally need not be disconnected from the car radio. Simply connect a single wire from the un-grounded side of the speaker to the "external speaker jack" on the Galaxy. NOTE! If you find neither speaker lead in the car radio is grounded, we recommend that a DPDT switch be installed to switch both voice coil leads from the car radio to the Galaxy. Caution! Be sure to switch the speaker to the unit in use to prevent damage to audio transformers.

The G-300 DC supply has a built-in control relay which is operated by the switch S4 which is part of the Galaxy "Rec. A. F." control, providing remote control of the power supply directly from the Galaxy with no additional relays or control circuits needed. The G-300DC is provided with a low-resistance high-current AGU-40 fuse (WRL #AGU-40, @ .30¢ ea.) to protect against low voltage shorts. In case of a short on the 325 or 800 volt lines, the power supply will simply cease to operate until the short is removed, at which time operation will return to normal.

Once your mobile installation of your Galaxy 300 is completed, you will find more satisfactory, solid, consistent communication than you have ever experienced from an automobile in the pre-sideband days. And the 300 watt PEP, with effective increase in talk power due to the ALC, will outperform other competitive units.

### Section 3 OPERATION.

3-1 Tuning and operation, fixed station. Read section 2 for installation and set-up adjustments. **BE CERTAIN THE ANTENNA TO BE USED HAS AN SWR BELOW 2:1. SERIOUS DAMAGE TO THE GALAXY 300 FINAL AMPLIFIER AND RECEIVER INPUT SECTION CAN BE CAUSED BY OPERATION WITH A HIGH-SWR ANTENNA.**

After connection of antenna, power supply, and microphone, complete the S-meter and bias adjustments per section 2-3. Then measure SWR if at all possible. We highly recommend the CESCO REFLECTOMETER CM52 (WRL #86D006, --\$29.95) SWR meter. A technique for measuring SWR with no danger to the GALAXY even with a high SWR antenna is described below.

Turn REC R. F. full on, REC A. F. to half scale, BAND and GRID to desired band. Set load as follows: 80 meters--1-1/2; 40 meters--2; 20 meters--4. Adjust TUNE for maximum received signals. Connect SWR meter between the antenna coaxial feedline and the Galaxy coax connector.

Set TUNE-REC-TRANS switch to TRANS. Quickly adjust NULL for minimum reading on the Galaxy meter, then re-adjust for 1-1/2 on upper scale of Galaxy meter. Set SWR meter for "Forward Power" and SWR meter sensitivity for about 1/2 scale reading. Adjust GRID and TUNE for maximum on SWR meter, then reset NULL so that Galaxy meter is at 1-1/2 on top scale OR LESS. The object is to keep the carrier nearly balanced out, transmitting just enough power to operate the SWR meter. Set the SWR meter sensitivity near maximum, so that only a small amount of carrier need be supplied by the Galaxy.

Now set the SWR meter sensitivity control for full scale forward power, then switch to reflected power and read the Standing Wave Ratio of the antenna, per the instructions provided by the SWR meter manufacturer. If SWR is above 2:1 make necessary adjustments to antenna system to reduce to 2:1 SWR or less.

When the SWR is below 2:1, proceed with normal tune up, as described below.

Set BAND switch and GRID control for desired band; sideband switch for desired sideband; LOAD at 1 on 80; 1-1/2 on 40; 3 on 20; TUNE-REC-TRANS switch to TRANS. Adjust NULL control for about 200 milliamperes (2 on top scale of Galaxy meter) plate current. Adjust TUNE for minimum current, adjust GRID for maximum on meter.

Now set TUNE-REC-TRANS switch to TUNE. Adjust LOAD for 400 milliamperes plate current (4 on top scale of meter). Adjust TUNE for minimum meter reading. Repeat adjustment of LOAD and TUNE until minimum is at 4 on meter top scale. Adjusting "TUNE" for minimum must be the final step.

Set TUNE-REC-TRANS back to TRANS. Adjust NULL for minimum meter reading. Set TUNE-REC-TRANS back to REC. Operate the push-to-talk switch, or speak into the mike on VOX-equipped units, and advance the "MIC." control until the meter reads 1-1/2--2-1/2 on voice peaks for a full power 300 watt PEP SSB signal. Release the push-to-talk switch, or simply stop talking on VOX-equipped units, to receive signals. It is simpler than it sounds; with practice, handchange and tune-up takes less than 20 seconds.

For CW operation, tune up as described above. Set the MIC control full counterclockwise (off), plug in key, and operate, using the TUNE-REC-TRANS switch with the switch in TUNE position to transmit. Either sideband may be used. The Galaxy 300 may be loaded to a full 400 milliamperes for CW. Power output will be 200 watts or more.

For AM operation, tune up as for sideband, then set NULL control for 190 milliamperes plate current. Set MIC so that there is a slight flicker of the meter when talking, no more than a quarter of a unit of the upper meter scale. Either sideband may be used. Only one sideband, plus carrier, will be transmitted. Which sideband will provide best communication depends on the QRM situation. In the absence of interference, either will be satisfactory. Excessive use of AM is not recommended, as it is much harder on the 6HF5 final amplifier tubes than the sideband operation for which they were designed. Keep transmission under 5 minutes to prevent overheating.

3-2. Tuning and operation, mobile station. Tuning and operation in mobile use are basically identical to fixed station operation, and reference is made to section 3-1 for details. BY ALL MEANS MEASURE THE ANTENNA SWR, AND ADJUST FOR LESS THAN 2:1. Use the reduced carrier method described in 3-1 to eliminate possible damage to the Galaxy during antenna adjustment.

With low battery voltage or excessive primary cable length to the G300-DC power supply, it may be impossible to load to a full 400 milliamperes of plate current, as the power supply may tend to pull out of oscillation. Pay attention to the mobile installation instructions in section 2-7 for best results. However, if this situation occurs, successful tune-up can be achieved by "sneaking up" on the 400 milliamperes current by completing the entire tune-up with the TUNE-REC-TRANS switch in the TRANS position, gradually setting the NULL control for higher and higher meter reading, then adjusting the TUNE and LOAD controls for maximum output, then re-setting the NULL control for minimum meter reading after tune-up is completed. Depending on battery and generator-alternator voltage settings, and 12 volt cable length and connections, maximum load may be as low as 350 milliamperes.

The OFF position of the REC A.F. control operates a switch brought out to pins 4 and 7 of the power plug. This is used to operate the control relay of the G-300 DC supply, and serves as a master "On-Off" switch in the mobile installation.

VOX is not recommended for mobile use because of the high ambient noise level in most cars. However, if the VOX GAIN is kept low and a close-talking microphone technique is used, VOX operation is practical.

In all other respects, mobile operation is identical with fixed station operation, as detailed in section 3-1.

High power mobile operation requires frequent inspection of the car battery. Keep the water level up, terminals free from corrosion, battery close to full charge. Measure battery condition with a hydrometer. Specific gravity reading should be as recommended by the battery manufacturer and will average near 1.260 for most batteries in good condition. Checking battery condition is especially important in the winter.

3-3 Operation outside the normal tuning range.

Operation between the following limits is possible simply by setting the main tuning dial beyond the calibrated frequency marks: 3790 to 3800, 4000 to 4020, 7350 to 7360, 7040 to 7050, 14,400 to 14,410, 14,180 to 14,200.

By adjustment of the VFO slugs and trimming capacitors, coverage of as much as 100 kc. beyond the marked band limits can be achieved, but this will destroy normal calibration of the VFO. It may also be necessary to retune the RF coils L2 through L7. For these reasons, such operation is not recommended if the unit is also to be used in normal amateur service.

## Section 4 Theory of Operation.

**4-1 Controls.** This section discusses the function of each control on the Galaxy 300.

### (a) Front panel controls.

**Frequency.** A two speed drive with 12:1 and 72:1 ratio controls the frequency of both the receiver and transmitter portion. Calibrated every 5kc. on all three bands.

**MIC.** Gain control for the transmitter audio circuits. Outer knob of a dual pot.

**REC A. F.** Gain control for receiver audio output. Inner knob of dual pot, with MIC. control. Also switch for control of G-300 DC power supply.

**Sideband switch,** marked "U 40, 1.80-20" and "L-40, U 80-20". In left position transmits and receives upper sideband signals on 40 meters and lower sideband on 80 and 20. In right position, transmits and receives lower sideband on 40 and upper sideband on 80 and 20 meters.

**BAND switch.** Selects circuits for operation on the 80, 40 or 20 meter bands.

**NULL.** Adjusts carrier suppression. Also used to unbalance carrier for AM operation and tuneup. Outer knob of dual control.

**REC R. F.** Controls R. F. and I. F. gain of receiver by inserting negative voltage into the AVC system. Used to reduce gain when copying strong signals in the presence of noise or QRM. Inner knob of dual pot with NULL. control.

**TUNE-REC-TRANS switch,** Sets transceiver circuits for tune up, receive, or transmit operation. In normal operation is left in REC position, and push-to-talk or mike or VOX accessory is used to go to transmit.

**GRID.** Adjusts tuning of the plate circuit of the transmit mixer V4 (6BA7) for maximum grid drive to the final amplifier.

**LOAD.** Adjusts proper loading of the plate circuit of the final amplifier, V1 and V2 (6HF5's).

**TUNE.** Adjusts tuning (resonance) of the plate circuit of the final amplifier, V1 and V2 (6HF5's).

### (b) Rear panel controls.

**Bias adjust.** Sets bias and zero-signal plate current of the final amplifier.

**Ext. Amp. Control.** Plug in for operating an external relay to control a linear amplifier. Plug is grounded on transmit.

S-meter adjust. Sets S-meter to zero with no signal input.

Power plug. To connect to power supply.

Key. Jack to plug in key for CW operation.

Spkr. Jack to plug in external speaker or earphones.

Mic. Jack to plug in microphone. Uses 3-circuit plug with .206" diameter sleeve, such as Switchcraft S-230 or S-260

(c) Internal controls.

Quadrature balance. Adjust for best carrier null, in conjunction with NULL control on front panel.

Neutralizing capacitor. Adjusts neutralizing of final amplifier V1 and V2 (6BF5's).

The slugs in the various IF and RF cans are detailed in section 5-5, "Alignment."

#### 4-2 Circuits.

The Galaxy 300 Transceiver is a crystal-filter unit with ALC, AGC, 300 watt PEP transmitter input, and 1.0 microvolt receiver sensitivity for 10db S/N ratio. The block diagram below shows the tubes and type of circuits used to achieve this performance. We will follow the signal through the Galaxy first in the transmit direction, then in receive.

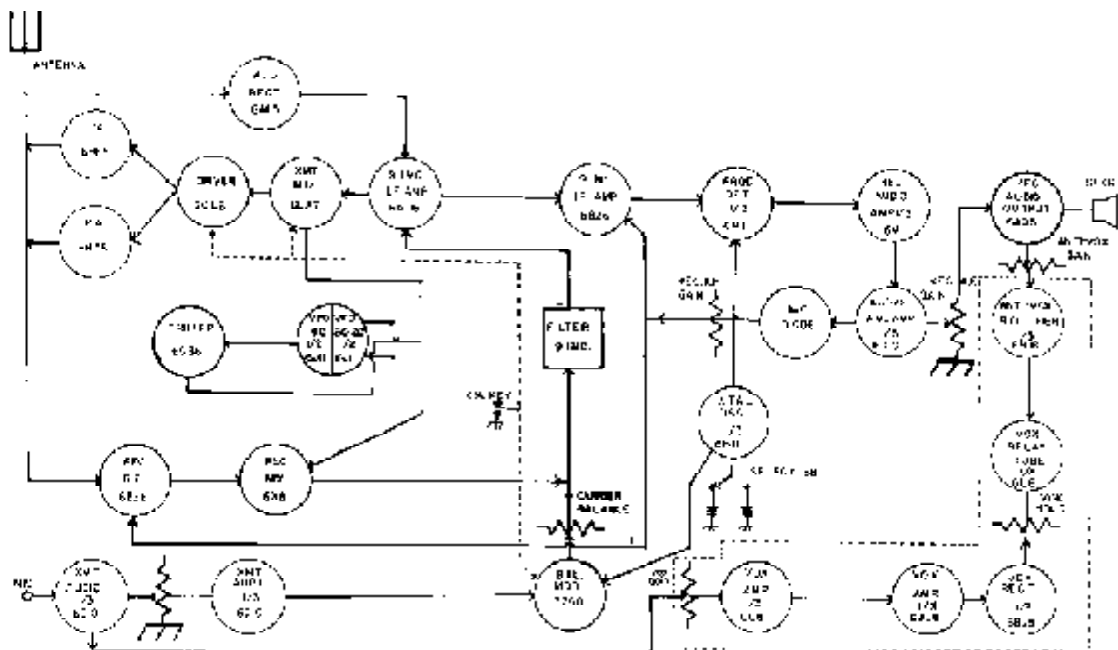

FIGURE E. BLOCK DIAGRAM



In transmit, begin at the MIC input, lower left. The microphone audio signal is amplified in two triode sections of a 6D10 triple triode. The amplified audio is fed to a deflection plate of a 7360 balanced modulator tube. The pentode section of a 6M11 serves as a crystal oscillator at 9098 or 9102 kc. (approximately), and feeds this RF to the control grid of the 7360 balanced modulator. The 7360 combines the audio and the RF to put out a double sideband suppressed carrier signal at 9098 for upper sideband or 9102 for lower sideband. The DSB signal passes through the 9100 kc filter which allows one sideband only to reach the 6AH6 9100 kc. L.F. amplifier. This is now a single sideband suppressed carrier signal. The amplified SSB signal at 9100 kc. is fed from the 6AH6 to the 6BA7 transmit mixer. A signal at 5100 to 5300 kc from the VFO for 80-20 meter operation, or from the 6CB6 tripler at 16,150 to 16,450 kc for 40 meter operation, is also fed into the 6BA7 transmit mixer. The sum or difference frequency, which is the desired output frequency, is selected by tuned circuits and fed to the 6CL6 driver. The 6CL6 output feeds the final amplifier, a pair of 6HF5's. The 6AL5 ALC rectifier detects any trace of grid current in the 6HF5's, and develops a bias voltage which is applied to the 6AH6 to reduce the L.F. gain whenever grid current flows, thus keeping the final in class AB1 and reducing distortion while increasing effective talk power. The plates of the 6HF5 final amplifiers are connected to the pi-network output circuit. In CW operation, the 7360, 6BA7, and 6CL6 are grid block keyed.

In receive operation, the incoming signal in the 6HF5 pi-network plate circuit is coupled to the 6BZ6 receive RF stage. The output of the 6BZ6 is fed to the 6X8 receive mixer. VFO signal from the VFO for 80-20 or from the tripler for 40 meters is fed to the 6X8 through a cathode follower utilizing the triode half of the 6X8, which prevents oscillator pulling. The 9100 kc. output of the 6X8 is fed through the 9100 kc. crystal filter to the 6AH6 L.F. amplifier, which is used in both receive and transmit. The output of the 6AH6 is further amplified in the 6BZ6 L.F. amplifier, then fed to a triode section of the 6M11 connected as a product detector. The pentode section of the 6M11, the crystal oscillator, feeds the 9098 or 9102 kc. crystal signal to the product detector section of the tube. The result is an audio signal which is amplified in the second triode section of the 6M11 pentode-dual triode. The audio is further amplified in the remaining triode section of the triple-triode 6D10. The output of this stage feeds both the AVC high back resistance crystal diode and the REC. A.F. gain control. The REC. A.F. gain control provides audio to the 6AQ5 receiver audio output, which drives the loudspeaker. The AVC diode, through a filter network, provides a negative voltage to the control grids of the 6BZ6 RF and the 6BZ6 LF tubes to decrease the gain with an increase of incoming signal strength, holding the audio output nearly constant over a wide range in incoming signal levels. The S-meter operates in a bridge circuit tied to the screen voltage of the two 6BZ6 tubes.

The VOX circuitry, an optional plug-in unit, is shown in the dotted lines at the right of the block diagram. The VOX uses a 6BJ8 triode-dual-diode and a 6L8 triode-pentode. One diode of the 6BJ8 serves as a rectifier for Anti-vox, obtaining its audio voltage directly from the 6AQ5 plate circuit, and

feeding negative bias to the 6BJ8 keying diode. The 6U8 pentode and 6BJ8 triode are amplifiers for the microphone audio, and feed amplified audio to the 6BJ8 keying diode. This diode controls the bias on the triode section of the 6U8, which acts as the relay control tube. Controls are provided for gain in the Anti-vox channel, gain in the VOX channel, and hold-in time of the relay tube.

Needless to say, there are many portions of the circuitry not discussed above, including the biasing networks which shut off the transmit tubes in receiving, and shut off the receive tubes while transmitting, the 7360 balancing network, the operation of the crystal filter, etc. Section 5, Servicing and Trouble Shooting, goes into more detail.

4-3 PSA-300 A.C. Power Supply, Theory of Operation, The PSA-300 utilizes silicon diodes in a bridge arrangement to supply the 315 and 800 volt outputs. The bias output is obtained from a half-wave silicon diode rectifier. The bias and 315 volt output use R-C filters. The 800 volt output uses an L-C filter with the choke tuned to approximately 120 cycles by C20, a .1 mfd 2500 volt paper capacitor. This tuning of the choke greatly improves the regulation of the 800 volt line from no load to full load. The R+switch operates a relay which controls the high voltages and increases operator safety by removing high voltage from the front panel switch. A loudspeaker is built into the PSA-300. The fuse is rated at 8 amperes.

The PSA-300 is also available with an electric clock, either factory installed (#66-038) or an optional kit that can be added in the field (#66-039, \$15.95). The clock can be set to the correct time without removing the power supply from the cabinet. Tilt the PSA-300 up on its right side, and use the eraser end of an ordinary lead pencil to reach through the square hole below the clock on the bottom of the cabinet to adjust the hour and minute wheels. Do not attempt to adjust the second wheel other than by setting the clock ahead a minute or two, then unplugging the supply from the wall socket until the actual time catches up with the clock.

G300DC Power Supply. This unit is designed to operate from 12 volts DC and deliver all voltages necessary for full power operation of the GALAXY. A toroidal transformer with a special saturable core is used with four power transistors in a 1000 cycle square wave oscillator. This oscillation is stepped up to the three desired output voltages by three windings on the toroidal transformer. The bias voltage is rectified by a half-wave silicon diode. The 315 and 800 volt outputs are rectified by full-wave silicon diode bridge circuits. Due to the high frequency of oscillation compared to the AC supply (1000 cycles vs. 60 cycles) only capacitive filtering is needed, although an R.F. choke has been added to the 800 volt line to suppress a slight hash. The G-300DC includes a relay which controls both filament power to the GALAXY, and primary power to the G-300DC. This relay is controlled by a switch on the "REC. A. F." control on the GALAXY.

5-1 (g) GALAXY 300 Voltage readings. Conditions: Receive Operation, 80 meters, Lower sideband, "REC R. F." full on. No signal input. Meter: Hewlett Packard 410R.

TUBE	1	2	3	4	5	6	7	8	9	10	11	12	Cap
6BF6(a)	5.9AC	0	0	0	-50(a)	0	0	0	-50(a)	0	0	0	830
6BF6(b)	5.9AC	0	0	0	-50(a)	0	0	0	-50(a)	0	0	11.5AC	830
6AD6(c)	0	0	0	0	0	0	0	0	0	0	0	0	0
6BZ6(RF)	-0.8(b)	0	5.9AC	11.5AC	320	104(c)	0	0	0	0	0	0	0
6CL6	0	-40	320	5.9AC	0	320	0	320	-90	0	0	0	0
6X8	0	0	104	5.9AC	11.5AC	2.6	0	100	250	0	0	0	0
6BA7	250	-80	0	5.9AC	11.5AC	0	0	0	250	0	0	0	0
6AH6	-1.6	0	11.5AC	5.9AC	245	145	0	0	0	0	0	0	0
6BZ6(IF)	-0.4	0.95	5.9AC	11.5AC	245	105(c)	0	0	0	0	0	0	0
6M11	11.5AC	-1.0	95	1.5	0	95	80	0	4.2	0.14	245	5.9AC	0
7300	0	250	-90	5.9AC	11.5AC	250	250	22(d)	22(d)	0	0	0	0
6AQ5	0	0	5.9AC	11.5AC	310	175	0	0	0	0	0	0	0
6D19	5.9AC	0	0.8	3.6	42	0	-0.7	0	0	0	0	0	0
6A2(VFO)	142	0	0	0	142	0	0	0	0	0	0	0	0
6CB5A	-0.55	0	0	5.9AC	-1.0	-1.0	0	0	0	0	0	0	0
6J11	5.9AC	-1.0	-1.0	0	-1.1	0	104	0.2	142	0	-3.4	0	0
6AL5	-0.9	-0.9	5.9AC	0	0	0	-1.7	0	0	0	0	0	0

Set bandswitch to 40 meters. Read the following voltages on 6J11 and 6CB6A.

6J11	5.9AC	104	142	0	-3.2	0.2	-0.8	0	-0.8	0	-0.8	0	0
6CB6A	-9.0	2.3	0	5.9AC	142	120	2.3	0	0	0	0	0	0

(a) Depends on setting of "bias adjust" control.

(b) Measured with "Rec. R. F." full on. With "Rec. R. F." off, -17 volts.

(c) Measured with "Rec. R. F." full on. With "Rec. R. F." off, -180 volts.

(d) Varies from 18 to 26 volts with setting of "Null" control.

5-1 (b) GALAXY 300 Voltage readings. Conditions: Transmit Operation, 80 meters, lower sideband, full carrier inserted, loaded to 400 milliamperes into dummy load. Meter: Hewlett Packard 410B.

TUBE	1	2	3	4	5	6	7	8	9	10	11	12	Bottom of Plate choke
61F5(1a)	5.9AC		145	0.8	-85	145		145	-85	0.8	145	0	780
61F5(1b)	5.9AC		145	0.8	-85	145		145	-85	0.8	145	11.5AC	780
6A2(Xmt)	145				145		0						
6BZ6(R1)	-320(a)	0	5.9AC	11.5AC	320	-32	0						
6CT6	4.4	0	240	5.9AC	0	320	4.4	240					
6X8	0	-3.0	-36	5.9AC	0	0	-105	-20	-20				
6B5A	09	-2.0	4.53	5.9AC	11.5AC	0	-0.3		250				
6B16	-1.5	0	11.5AC	5.9AC	245	120	0						
6BZ6(P1)	-270(a)	0	5.9AC	11.5AC	245	-32	0						
6W7	11.5AC	-1.1	20	1.5	0	95	BB	0	3.8	0.15	245	5.9AC	
7360	4.3	168	0	5.9AC	11.5AC	130(b)	-30(b)	22(a)	22(c)				
6AQ3	-105	0	3.9AC	11.5AC	320	-13	-105						
6D10	5.9AC	60	0.92	0	43	0	-0.75	0	-0.43	-17.5	0	0	
6A2(VTO)	145			0	148								
6CB6	-0.95	0	0	5.9AC	-1.0	-1.0	0						
6J11	5.9AC	-1.0	-1.0	0	-1.1	0	105	0.2	145	0		-3.4V	
6AL5	-0.8	0.8	5.9AC	0	0		-1.5						

Set bandswitch to 40 meters. Tune and load for 400 milliamperes plate current. Read the following voltages on 6J11 and 6CB6A.

6J11	5.9AC	104	145	0	-3.2	0.2	-0.8	0	-0.8	0	-0.9	0
6CB6A	-0.0	2.3	0	5.9AC	145	122	2.3					

- (a) Varies with RF level, -90 with carrier nulled out.
- (b) Varies 100 to 180 volts with setting of the null control.
- (c) Varies 18 to 26 volts with setting of the null control.

5-1 (c) Galaxy 300. R. F. Voltages at specified points.

Conditions: Full carrier inserted, 50 ohm dummy load. Tuned up for 400 milliamperes plate current. Meter: Hewlett Packard 410B.

	80 Meters	40 Meters	20 Meters
VFO out	2.4	Junction C43-44	3.8
6RA7 pin 2	1.5		2.4
6V11 pin 10	1.05		1.1
6M11 pin 11	2.5		2.5
6C18 pin 6	60 to 85		60-85
61E5-V1-pin 5 & 9	60 to 85		60-85
61E5-V2-pin 5 & 9	60 to 85		60-85
Output Jack	100		100
73E0 pin 3	2.7		2.2
Receive operation. No signal input. REC. R. F. full on.			
Tripler out			
VFO out	2.4	Junction C43-C44	3.4
6M11 pin 10	1.2		1.2
6M11 pin 11	2.8		2.8
6X8 pin 2	1.25		2.2
6X8 pin 6	0.75		1.1
6M11 pin 9	2.75		2.75

A signal of approximately 30 microvolts injected into pin 1 of the 6AH6 at 9,100 mc. should produce an S-9 or higher reading. A signal between 10 and 50 microvolts injected into the coax jack of the Galaxy at signal frequency should produce an S-9 meter reading. 1.0 microvolt should produce 10 db. signal to noise ratio.

5-1 (d) GALAXY 300 Resistance measurements. Conditions: Power cable unplugged, Bandswitch on 80, Side-band switch at "L80-20", REC A.F. full on, REC. R.F. full on, N.U.I. in center of range, Quadrature in center of range. TUNE-REC-TRANS switch at REC. Meter: Hewlett Packard 410B.

TUBE	1	2	3	4	5	6	7	8	9	10	11	12	Top Cap
V1-5HF5 edge	0.2	NC	27K	2.0	6 to 9K(a)	27K	NC	27K	6 to 9K(a)	2.0	27K	0.0	open
V2-6HF5 center	0.2	NC	27K	2.0	6 to 9K(a)	27K	NC	27K	6 to 9K(a)	2.0	27K	0.4	open
V3-6CL6	10C	127K	33K	0.2	0.0	18K	100	33K	127K				
V4-6BA7	36K	156K	47	0.2	0.4	0.0	47K	NC	18K				
V5-6M11	0.4	100K	118K	2.2K	220K	240K	118K	0.4	2.2K	20	18K	0.2	
V6-6J11	0.2	open	open	0.0	33K	30	open	open	open	0.0	47K	0.0	
V7-6CB6	100K	45K(b)	22K(b)	0.2	open	open	45K(f)	30	22K(f)				
V7-6CB6 final		470	0.0	0.2	18K(b)	40K(b)	470						
V8-0A2 screen	27K	0.0	open	0.0	27K	open	0.0						
V9-6AF5	open	open	open	0.2	0.0	open	3.3Meg.						
V10-6BZ6-RF	3.2Meg.	0.0	0.2	0.4	18K	24K	0.0						
V11-6X8	0.0	100K	37K	0.2	0.0	470	3.2	57K	19K				
V12-0A2-VFO	22K	0.0	open	0.0	22K	open	0.0						
V13-6AQ5	0-230K(c)	470	0.2	0.4	18K	16K	0-250K						
V14-6D10	0.2	250K	1K	3.3K	250K	0.0	1.0Meg.	0.0	270K	54K	0-1.0	0.0	
V15-7369	1.2K	100K	147K	0.2	0.4	87K	87K	53K	53K				
V16-6AH6	3.3Meg	0.0	0.4	0.2	19K	65K	0.0						
V17-6BZ6IF	2.3Meg	100	0.2	0.4	19K	24K	0.0						
Relay	0.0	0.0	18K	1K	56K	open	30K	2.0	0.0	0.0	18K	1K	
Power Plug	open	NC	18K	open	1Meg(e)	0.4	NC	0.2	7K	0.0	open	0.4	

- (a) Varies with setting of bias control.
- (b) Open on 80 & 20, reads on 40.
- (c) Varies with setting of REC A.F. control
- (d) Varies with MIC. gain control.
- (e) Reads resistance of diode D4. Depends on meter.
- (f) Open on 40, reads on 80 & 20.

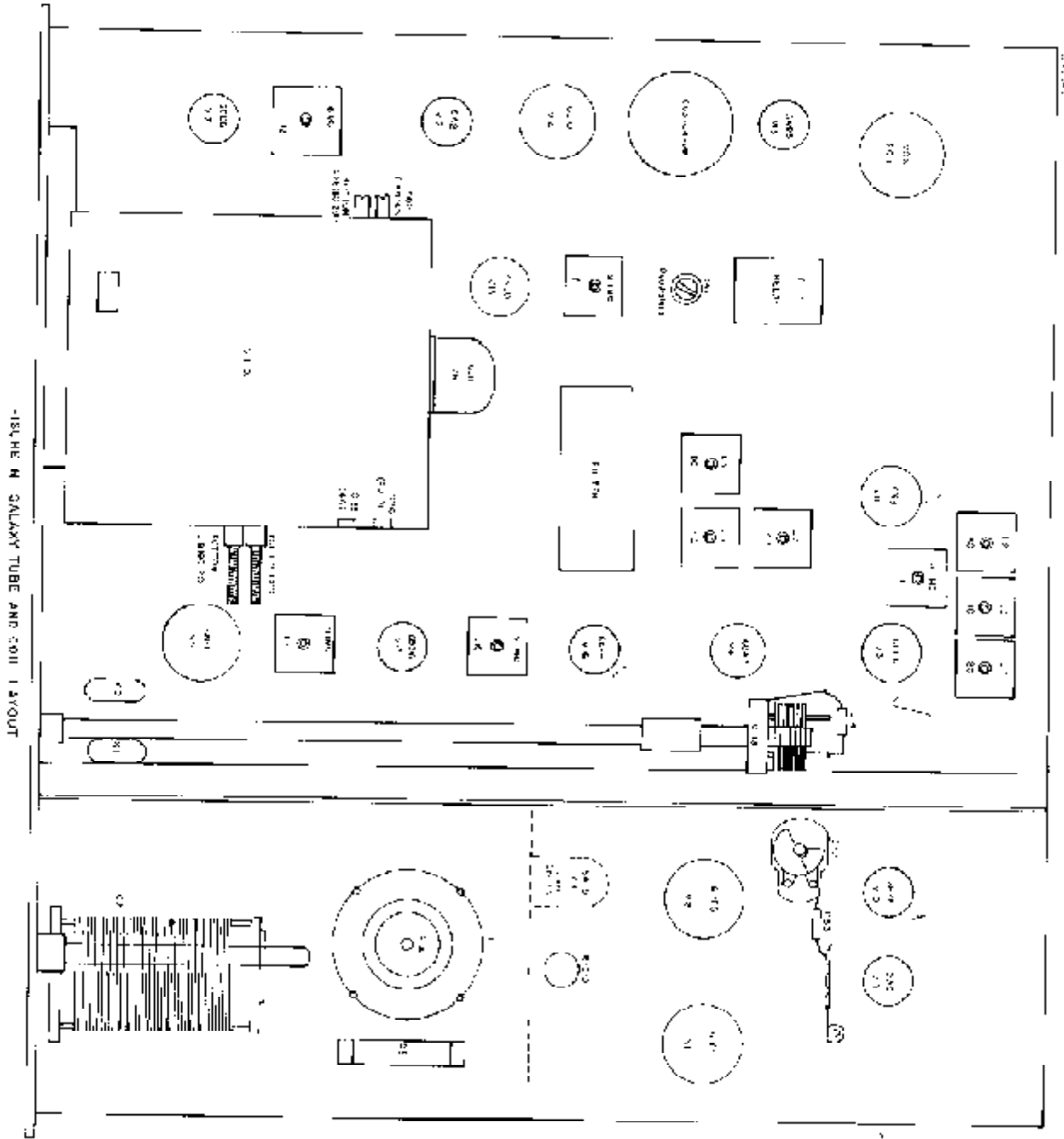

-15U HE N GALAXY TUBE AND COIL LAYOUT

5-2 (a) PSA-300 A. C. Power supply voltage and resistance measurements. Conditions: No load (unplugged from GALAXY), A. C. line at 117 volts, A. C. and B+ switches on, measurements made from chassis except resistances of choke and transformer windings. Meter: Hewlett Packard 410B. Full load readings taken on GALAXY in transmit and loaded to 400 milliamperes.

USE EXTREME CAUTION. VOLTAGES DANGEROUS TO LIFE ARE PRESENT IN THIS EQUIPMENT. USE CAREFUL!

LOCATION	1	2	3	4	5	6	7	8	9	10	11	12
Output plug no load	900	0	370	0	0(a)	12.9AC	0	5.45AC	-110	0	0	0
Output plug Full load	800	0	310	0	12.2AC	12.2AC	0	6.1AC	-105	0	0	0

RESISTANCES MEASURED WITH SUPPLY UNPLUGGED FROM A. C. AND FROM GALAXY. DISCHARGE CAPACITORS BEFORE MEASURING!

Output plug	open/30K(b)	open/15K(b)	open	0.1	open	0.05	10K	0.0	open	3.0
-------------	-------------	-------------	------	-----	------	------	-----	-----	------	-----

Resistance across CH-1, 55 ohms.

Resistance across transformer T-1 windings: Primary (black leads) 0.4 ohm. High voltage (red leads) 51 ohms. Low voltage (orange leads) 17 ohms. Bias (blue leads) 6 ohms.

(a) Pin 5 is jumpered to pin 6 in the cable. With the cable unplugged from the PSA-300, 0 volts on pin 5. When cable is plugged in to connect PSA-300 to load, filament voltage appears on pin 5.

(b) This resistance appears when the relay is held shut manually.

Diodes can be checked with the ohmmeter. Should read high with meter connected one way and low with meter connected opposite polarity across diode. Out of circuit, above 2 megohms back resistance.

5-2 (b) G-300DC power supply. Voltage and resistance measurements. Conditions: no load (unplugged from GALAXY), D. C. supply voltage held at 13.0 volts. Measurement made from ground, pin 7. Meter: Hewlett Packard 410B. Full load readings taken on GALAXY in transmit and loaded to 400 milliamperes.

LOCATION	1	2	3	4	5	6	7	8
Output plug no load	13	13	-108	370	950	0	0	13
Output plug full load	13	13	-100	325	810	0	0	13
Resistance at Output plug	open (c)	open (c)	6.5-10K	10-80K	200K	open (c)	open (c)	0.5-40(c)

(c) May show slight leakage. (d) Depends on polarity of ohmmeter. (e) Measure relay coil, pin 2 to pin 6. 100 ohms. If open, check fuse.



5-3 (a) VX-1 VOX unit voltage chart. Measured with 2-1/2 foot extension cable, plugged into operating GALAXY. Receive readings taken with VOX GAIN half open. No signal on receive except where otherwise noted. Transmit readings taken with VOX GAIN at PTT and microphone PTT closed, carrier nulled out. Meter: Hewlett Packard 410B.

TUBE	Voltages, receive			Voltages, transmit														
	Pin number	Pin number	Pin number	1	2	3	4	5	6	7	8	9						
6B16	-1.2 -100 (a)	0.1 13 (a)	12AC -5.04 (a)	5.2AC -100 (a)	-1	126	0	4.8	-1.2	0.2	0.4	12AC	6.2AC	-1	120	0	4.6	
6U8A	310	0	65	5.2AC	0	1.75	13	0.1	100	0	62	5.2AC	0	102	1.7	2.7	0.4	
Relay(h)	300	17	0	310	310	310	Mic, Audio	0	190	300	0	0	0	0	0	0	0	
5C2-1	0	12AC	13	17	310	6.2AC	310	Mic, Audio	0	12AC	0	0	300	6.2AC	300	6.2AC	300	Mic 300 Audio

5-3 (b) VX-1 VOX unit resistance chart. Measured with VX-1 unplugged from GALAXY. Meter: Hewlett Packard 410B.

TUBE	Pin Number			Pin Number								
	Pin number	Pin number	Pin number	3	4	5	6	7	8	9	0	
6B16	370K	0-100K(e)	0-100K(e)	820K-1, 8Meg (d)	4.0	2.0	500K	130K	450K	2.2K	0	
6U8A	35K	220K-720K(e)	220K-720K(e)	850K	2.0	0	250K	1.5K	1.0K	820K-5, 8Meg(d)	0	
Relay	5.0K from pin 1 to pin 2	0	0	open	0	open/(g)	open	open	open	open	open	
P-1	0	4.0	4.0	open/1.1K(f)	open/(g)	open	2.0	29K	open	open	open	

(a) first figure with REC. A. F. off (counterclockwise), second figure with REC. A. F. full on (clockwise) and a strong signal tuned in for approximately a 1000 cycle beat note.

(b) 1 & 2 are relay coil. #1 is connected to 6U8A pin 1. #3 is lower fixed contact. #4 is moving contact.

(c) Varies with setting of "ANTI-VOX" control.

(d) Varies with setting of "HOLD TIME" control.

(e) Varies with setting of "VOX GAIN" control.

(f) Open with "VOX GAIN" advanced, 1.1 K with "VOX GAIN" at "PTT".

(g) 0 when relay is manually closed.

5-4 Trouble shooting symptoms and cures.

<u>SYMPTOM</u>	<u>CURE</u>
Carrier frequency shifts when changing sidebands on 80/20.	Adjust C26, rear ceramic trimmer on right side of VFO for no shift at 3900 kc.
Carrier frequency shifts when changing sidebands on 40.	Adjust C38, front ceramic trimmer on right side of VFO for no shift at 7250 kc.
Hum in receiver with "REC. R. F." control turned off (counterclockwise).	Change 6M11, 6D10. Check C63, C68.
Hum in receiver with "REC. A. F." control turned off (counterclockwise).	Change 6AQ5. Check C64, C65.
Hum in transmitter which clears up when "MIC" control is turned off.	Change 6D10. Check microphone for broken wire or shield.
Hum in receiver on one sideband only.	Change C94, .01 on sideband switch. Replace crystal. Re-neutralize final amplifier.
Carrier will not null to -40db or better, or will null on one sideband but not the other.	Change 7360. Readjust R47 quadrature control while adjusting NULL control. Re-align all 9.1 Mc. circuits.
Voice too low pitched. Poor sideband suppression, poor carrier suppression.	Carrier shifted too far into passband. Readjust crystal trimmer. See ALIGNMENT. (5-3).
Voice too high-pitched. Good sideband and good carrier suppression.	Carrier shifted too far out of passband. Readjust crystal trimmer. See ALIGNMENT. (5-5).
Transmitter cannot be loaded to 4 on top scale on any band, or can be loaded on one sideband but not the other.	On receive, turn "REC. R. F." full counterclockwise. Meter should pin on right. If not, replace meter. If meter OK, <u>CHECK ANTENNA SWR</u> . Re-align 9.1 mc stages. Re-align L2 through L7 and L12. Re-align C21 and C22.
Transmitter loads OK 80 & 40, low on 20.	Realign 9.1 Mc. cans and L4 (42-16) and L7 (42-10). Replace 6BA7, 6CL6.
Receiver dead, low drive on transmitter.	Leaky C45. Replace. Leakage biases off 6AH6, dropping gain on transmit & receive.
S-meter erratic or non-operative.	Replace Diode D3.

Push-to-talk relay non-operative

Replace Diodes D1 and D2.

Push-to-talk relay chatter.

Replace R85.

Transmitter operates OK, but no control peaks visible on the basis marking

Adjust R17 (42-17) for 80, L6 (42-18) for 20 or L7 (42-18) for 20 with GRID on 100000 volts.

Backlash in frequency dial.

Replace split gear for two teeth spring on the dial ion. Be careful not to upset frequency calibration.

VOX chatter.

Insert over hinge of cabinet should not touch VOX chassis. Put tape on VOX chassis on early models. Replace push-to-talk relay-in relay. Re-set VOX GAIN control on VOX.

REC. R.F. gain too low, or fluctuation on 5 meter band, or on any other band.

Check for loose terminal strip on 5 meter band, or 500 per current position.

Untuneable signal, or signal louder on 500 than on higher bands changing sidelands.

Adjust R100 for minimum signal. Check for stray leakage, noticeable at 500 areas at night on some antennae.

Receiver sensitivity low, or weak, or drive low on 500.

Adjust R143-200 for maximum sensitivity on 500. Put on 10.

Receiver use flat on 500.

Check for loose CRFB's.

Receiver use flat on low stages only.

Check for loose diodes like to 7360-6CL6. Check for loose screen bypass capacitors.

Transmitter gain too low, or "flat" and "blong" sound on 500 on each band.

Check for loose 4E and 1E.

Receiver gain low, or flat, or very low gain on 500, or very low on other bands.

Check for loose 100-1745 miniature coax. Check for loose 9.1 and 5.4 capacitors (100-200) and 5.4 capacitors. Check for loose wiring.

Plate circuit, or 500, or 3000 volt over 500, or 3000 volt over 3000, or 3000 volt over 3000.

Check for loose 3000 volt shorted capacitors.

"Hissing" or "explosion" in  
PSA-300, followed by blowing fuse.

Check C20 in PSA-300, and all electro-  
lytic condensers, for shorts. Check all  
diodes for open or short. Replace as  
needed.

In G-300DC, no output, no "sing-  
ing" of transistors, fuse does not  
blow.

Short on 800 or 315 volt line. Transistors  
go out of oscillation. Clear short and  
normal operation will return; supply will  
not be damaged by short on 800 or 315  
volt lines.

In G-300DC, fuse blows as soon as  
power is turned on.

Most likely short in 12 volt line or bad  
transistor. Unplug cable from GALAXY,  
start G-300DC by grounding pin 6. If  
supply operates, short is in GALAXY. If  
fuse blows, unplug cable and check cable  
for shorts. Then connect 12 volts to pins  
1 & 2 of G-300DC, ground pin 6. If fuse  
blows, check for shorted condenser, wir-  
ing, or bad transistor in G-300DC.

G-300DC operates normally on re-  
ceive, but on tuneup of transmitter,  
meter readings jump up and down.

The transistors are pulling out of os-  
cillation and output from the supply ceases.  
Cause is almost always insufficient volt-  
age at the G-300DC 12 volt input termi-  
nals under full load. Check cables, con-  
nections, condition of car battery.  
Measure voltage from pin 1 to pin 7 of  
G-300DC plug. Must be at least 12.5  
volts with GALAXY in "TUNE" and load-  
ed to 350 mils. For full 400 mil load,  
13.0 volts at G-300DC input terminals  
with engine running is needed. Alternator  
equipped cars have an advantage here.

## 5-5 ALIGNMENT.

This is a complicated apparatus, and alignment should not be attempted without a full understanding of the circuitry and adequate equipment. The GALAXY 300 can be returned to the factory for re-alignment, complete check and re-calibration, for only \$10.00, plus shipping.

The alignment is divided into three basic sections, (A) receiver, (B) transmitter, and (C) VFO. **DANGER! HIGH VOLTAGE! USE EXTREME CAUTION WHEN THE UNIT IS OUT OF THE CABINET, AS VOLTAGES DANGEROUS TO LIFE EXIST!**

(A) Receiver alignment. Equipment needed: calibrated signal generator with resistive pad (3 or 6 db, 50 ohm); 100 Kc crystal oscillator; calibrated receiver for 5,100 and 6,400 mc. See 2-1 and 5-1 for drawings.

1. Disconnect screen leads to both SHF5's or disable 800 volt power supply to prevent possible damage to signal generator by accidentally turning on the transmitter.
2. Connect signal generator to pin 10 GALAXY 300 antenna jack.
3. Apply power to GALAXY and allow 5 minute warm up.
4. Set "REC. R. F." full clockwise, "REC. A. F." half-scale, "TRANS-REC-TUNE" at "REC." "BAND" at 40. Sideband switch at "U 40". Adjust R64 (pot on center of chassis rear panel) for zero S-meter reading.
5. Set signal generator at 10,000 microvolt output, 9,130 mc.; vary generator frequency until beat note is heard in transceiver loud-speaker. Set "LOAD" at 2, adjust "TUNE" for maximum volume and S-meter reading. Set generator output level for approximately S-6 on GALAXY meter.
6. Adjust top and bottom slug in T-2 (73-2), the transformer nearest the 3M11, for maximum S-meter reading. Reduce the signal generator level to keep S-meter below S-9.
7. Adjust the slug of L-10 (73-4) transformer between 3BZ6 and 3AH6, for maximum S-meter reading. Reduce generator output as needed.
8. Adjust bottom slug only of F1 (73-3) transformer nearest 7360 tube, for maximum S-meter reading.
9. Adjust slug of L17 (42-21) transformer nearest 3X8, for minimum S-meter reading. This is a final step to eliminate signal leakthrough at IF frequency.

10. If the VFO calibration is within 25 kc, skip this step. Set "BAND" at 40, VFO dial at 7,100, C35 (top trimmer, left side of VFO as viewed from the front) at horizontal position of the screwdriver slot. Use an external receiver with a 100 kc. calibrator to listen to the oscillator signal at 5400 kc. Adjust the top slug on the right side of the VFO box for 5,400 mc. oscillator signal. Now set "BAND" to 80, VFO dial to 4,000, C28 (bottom trimmer on left side of VFO box) at horizontal position of screwdriver slot. Tune bottom slug on right side of VFO box for 5,100 oscillator signal in the external receiver.
11. Set "BAND" to 40, frequency to 7,200 mc. Set signal generator to 7,200 mc., adjust generator until signal is heard in the GALAXY. Set "LOAD" to 2, adjust "TUNE" for maximum S-meter reading. Reduce generator output until S-meter reads S6. Adjust L12 (42-20), can adjacent to CCB6, for S-meter maximum. Reduce generator output for S-6 reading again. Adjust L3 (42-15), center can at rear of chassis for S-meter maximum.
12. Set "BAND" to 80, frequency to 3,900, "LOAD" to 1. Set signal generator to 3,900, adjust until signal is heard in transceiver. Adjust "TUNE" for maximum S-meter reading, set generator output for S-6 on GALAXY. Adjust L2 (42-14), left can on rear of chassis as viewed from front, for maximum S-meter reading.
13. Set "BAND" to 20, frequency to 14,300, LOAD to 3. Set signal generator to 14,300, adjust until signal is heard in transceiver. Adjust "TUNE" for maximum S-meter reading, set generator for S-6 meter reading. If any instability is noticed, adjust C52, neutralizing trimmer rear of 6HP5's to about 2/3 mesh, or until instability clears up. Adjust L4 (42-15), rear can nearest chassis shield partition, for maximum S-meter reading.
14. Reconnect 6HP5 screens or high voltage line disabled in step 1.

The receiver is now aligned. Calibration of the VFO is next. Do not recalibrate the VFO unless error exceeds 5 kc. For errors under 5 kc, move the adjustable hairline. (see section 2-1).

(3) VFO calibration. Equipment needed: 100 kc. crystal oscillator, calibrated receiver.

1. Set "BAND" at 40, VFO dial at 7,200. Turn on 100 kc. oscillator, place output lead near antenna jack of the GALAXY 300. Tune VFO dial until signal from 100 kc. oscillator is heard. Set "LOAD" at 2, adjust "TUNE" for maximum S-meter reading. Check with external receiver to be sure VFO is on 5,400 mc., not 100 kc. off frequency. Adjust top slug on right side of VFO for zero-beat with 100 kc. oscillator when dial is set at 7,200.

2. Tune to 7.300 and zero beat 100 kc. oscillator. Note number of kc. between zero-beat and the indicated 7.300 on the dial. Adjust C35, top trimmer on left side of VFO, to move VFO 20 kc. in the opposite direction for each 1 kc. of error between 7.300 on dial and zero-beat. Then use top slug on right of VFO to move the zero-beat back to 7.300 on the dial. Make very small-increment adjustments to eliminate the possibility of moving a full 100 kc.
3. Tune VFO dial back to 7.200. If zero beat is not at 7.200, use top slug, right side of VFO box, to set zero-beat at 7.200. Repeat steps 2 & 3 until both 7.2 and 7.3 are exactly on frequency. 7.100 should be within 5 kc.
4. Set "BAND" to 80, "LOAD" to 1, VFO frequency to 4,000. Check in external receiver that oscillator frequency is at 5,000 mc. Tune in external oscillator signal on GALAXY at 3,900, set "TUNE" for maximum S-meter reading.
5. Tune in 100 kc. oscillator signal at 4,000 mc. Adjust bottom slug on right side of VFO box for zero beat.
6. Tune VFO frequency to 3,800 mc. Note difference between dial at 3,800 and zero beat from 100 kc. oscillator. Adjust C28, bottom trimmer on left side of VFO, to move 8 kc. in the opposite direction for each 1 kc. of error. Then use bottom slug on right side of VFO to set zero beat to 3,800 mc.
7. Set VFO frequency to 4,000 mc. If zero-beat of 100 kc. oscillator is not at 4,000 on dial, use bottom slug on right side of VFO to set zero-beat. Repeat steps 6 & 7 until calibration is exact at 3,800 and 4,000. 3,900 should be within 4 kc.
8. Set "BAND" to 40 and re-check calibration. There is slight interaction between the 80 and 40 meter adjustments. It should only be necessary to "touch-up" the top slug, not the C35 trimmer.

The VFO is now aligned. 20 meters uses the same VFO as 80, so alignment is not necessary on this band. The crystal trimmers and the VFO shift trimmers on the right side of the VFO can will affect 20 meter calibration. They are adjusted in the next section.

(C) Transmitter alignment. Equipment needed: 50 ohm dummy load capable of handling 200 watts or more (Heathkit Antenna is suitable), 100 kc. crystal oscillator, oscilloscope or RF Analyzer such as Heath HO10 or Central Electronics MM-2, and an audio signal generator. A good VTVM or VOM can be substituted for the scope in case of emergency.

1. Connect equipment as follows: Dummy load to GALAXY antenna jack. Scope to GALAXY antenna jack. Audio oscillator to GALAXY mike jack using

3/16" sleeve three circuit plug (Switchcraft S-230 or S-260) with audio to ring and ground to sleeve. Audio level must be padded to approximately .02 volts at approximately 1000 cycles. If no scope is available, connect the RF probe of a VTVM to the antenna jack of the GALAXY. NOTE: MANY VTVM RF PROBES ARE RATED TO ONLY 25 VOLTS. THESE WILL BE BLOWN OUT BY THE GALAXY! THE RF PROBE MUST BE RATED FOR AT LEAST 100 VOLTS. If the Heathkit Antenna is used, a VOM or VTVM on a DC voltage scale can be connected to the rectified output jack on the Antenna. The primary purpose of the scope, VTVM or VOM is to serve as a calibrated output indicator. The scope will also give an accurate indication of both sideband and carrier suppression. The meter will indicate carrier suppression, but not sideband suppression. The output lead from the 100 kc. oscillator should be positioned near the GALAXY antenna jack; stray coupling will provide sufficient pickup.

2. Turn GALAXY on. Allow 30 minutes warmup. If transmitter alignment follows receiver alignment and the GALAXY has already been on for thirty minutes, proceed to step 3.
3. Set "TUNE-REC-TRANS" to REC. Set sideband selector switch to "U 40". Set "BAND" to 40, and frequency to 7,200 mc. Set "TUNE" to 5-1/2, "LOAD" to 1-1/2. Turn GALAXY on its left end. Adjust C21 and C22, the ceramic trimmers to the rear of the sideband selector switch as follows: The trimmer toward the front of the chassis to minimum capacity. The trimmer toward the rear of the chassis to maximum capacity. See sketch in step 9 of this section.
4. Set "GRID" to center of the 40 range. Set "TUNE-REC-TRANS" switch to "TUNE" and quickly adjust the "TUNE" control for minimum meter reading.
5. Set "TUNE-REC-TRANS" to "TRANS" and adjust "NULL" control for minimum meter reading. Adjust "Quadrature" control on chassis in front of plug-in relay for minimum meter reading. Adjust "Bias Adjust" on rear of chassis behind 6HF's for 80 milliamperes meter reading, or "S-2" on the lower meter scale.
6. Adjust "NULL" control for meter reading of 100 milliamperes, or "1" on the top meter scale. Adjust the slug in L5 (42-18), just left of the 6BA7, for maximum meter reading with the "GRID" control set in the center of the "40" range. Then adjust L3 (42-13), the center of the three coils at the rear of the chassis for maximum meter reading. NOTE: If meter reading increases to 300 milliamperes or higher (3 on top scale), use the "NULL" control to bring it back down to 1 or 1-1/2 before continuing adjustment of the coil slugs.
7. Set the "NULL" control full clockwise. Turn the "GRID" control toward the "80" mark until the meter drops to 1 or 1-1/2. Adjust the top and



bottom slugs of T1 (73-3), the transformer to the rear of the 7360, for maximum meter reading. The peak on the top slug will be broad; set to the middle of the peak.

8. Set "GRID" for the center of the 40 meter range. Set "NULL" for minimum meter reading. Turn "TUNE-REC-TRANS" to TUNE and adjust TUNE and LOAD controls for reading of 4 (400 milliamperes) on top meter scale, being sure to adjust "TUNE" for minimum meter reading after each adjustment of the "LOAD" control. Then set "TUNE-REC-TRANS" to "REC"
9. Set GALAXY on its left side. Set C21 and C22, the ceramic trimmers adjacent to the crystal sockets, as shown in the sketch below.

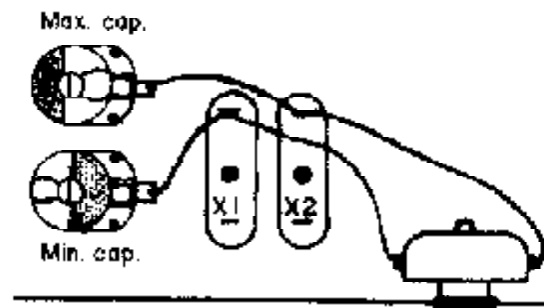

Figure L - Setting crystal trimmers

10. Set "TUNE-REC-TRANS" switch to "TRANS. Adjust "NULL" until meter drops to 200 milliamperes (2 on top scale). Set sideband switch to "L40". If the meter reading goes up, leave the sideband switch in the "L40" position. If the meter reading goes down, set the sideband switch back to "U40". Re-set "NULL" for a reading of 200 milliamperes, if necessary.
11. Observe the output voltage on the scope or RF voltmeter. If on "U40", adjust the rear trimmer for a 6 db. (one-half the voltage) drop in output. Then set the sideband switch to "L40" and adjust the front trimmer for the same output voltage. If on "L40" when beginning this step, adjust the front trimmer first for a 6 db drop in output, switch to "U40" and adjust the rear trimmer for the same output voltage. The object is to begin the setting of the crystal oscillator on the crystal that can be pulled furthest into the passband.
12. Set "GRID" to center of 40 range, "NULL" full clockwise, and check adjustment of "TUNE" and "LOAD" to be at dip and at 4 on top scale of meter. Now adjust "NULL" for minimum output indication on scope

or output meter, with sideband switch at "U 40". Also adjust "Quadrature" control on chassis near the 7360 for minimum. The two controls will interact, so repeat several times. A null should be reached where the output voltage is 1/100 or less of the maximum output voltage. This represents 40 db. down carrier suppression.

13. Set the sideband switch for "L 40". Repeat adjustment of "NULL" control. It should be possible to reach the same depth of null, or very close to it. It may be necessary to make a compromise setting of the "Quadrature" control, but should still be possible to reach 40 db. carrier suppression on either sideband with slight adjustment of the front panel "NULL" control.
14. Set the frequency at 7250 kc. Tune in the signal on an external receiver. Set the sideband switch to "U 40". Set receiver for a beat note around 500 cycles. Set the sideband switch to "L 40". If there is any change in the pitch of the beat note, adjust C38, the front ceramic trimmer on the right side of the VFO box. There should be negligible change in the output frequency when switching from upper to lower sideband. When this condition is reached, tune the external receiver for approximately a 1 kc. beat note and switch sidebands. There should still be no change. If there is, you have set one of the oscillators to the opposite side of zero beat.
15. Set "TUNE-REC-TRANS" to REC. Turn on 100 kc. oscillator. Tune in on 7200 and 7300 kc. with sideband switch in "U 40" position. Calibration may have changed slightly with the setting of the crystal oscillators. Repeat steps (B) 1, 2, and 3 of this section, VFO calibration, as needed.
16. Set "BAND" to 80, "GRID" to the center of the 80 meter range, frequency to 3900 kc, "LOAD" to 1-1/2, "TUNE" to 6-1/2. Set "TUNE-REC-TRANS" to TUNE and adjust "TUNE" control for minimum meter reading.
17. Set "TUNE-REC-TRANS" to "TRANS". Adjust "NULL" control for a meter reading of 1-1/2 on the top scale. Adjust the slugs of L2 (42-14) and L5 (42-17) for maximum meter reading. L2 is the left of the three coils at the rear of the chassis, as viewed from the front. L5 is the left of the two coils adjacent to the 6BA7.
18. Set frequency to 3800, "GRID" knob to left line (low end of 80). Repeat L5 (42-17) for maximum meter reading.
19. Set the sideband switch at "L80-20", "TUNE-REC-TRANS" to "REC". Turn on the 100 kc. oscillator and tune it in at 4000 kc. Check and adjust calibration as described in steps 5, 6 and 7 of 5-3 (B) VFO Calibration.

20. Set frequency to 3900 kc. Turn off 100 kc. oscillator. Set "TUNE-REC-TRANS" switch to "TRANS". Tune in signal on external receiver for about a 500 cycle beat note. Set sideband switch to "U80-20". There should be no perceptible change in the pitch of the beat note. Adjust C26, the rear ceramic trimmer on the right side of the VFO box as needed for no frequency change between upper and lower sideband.
21. Set "TUNE-REC-TRANS" to "REC". Set "BAND" to 20, "GRID" to the center of the 20 meter range, "TUNE" to 3, "LOAD" to 3, frequency to 14,300 kc.
22. Set "TUNE-REC-TRANS" to "TUNE". Adjust "TUNE" control for minimum meter reading.
23. Set "TUNE-REC-TRANS" to "TRANS". Adjust "NULL" for a reading on 1-1/2 on the top scale of the meter. Adjust the slugs in L4 (42-16) and L7 (42-19) for maximum meter reading. L4 is the right hand can of the group at the rear center of the chassis. L7 is the can just to the rear and the left of the 6BA7.
24. Turn "NULL" fully clockwise. Adjust "TUNE" and "LOAD" for 400 milliamperes plate current (4 on top meter scale).
25. Adjust "NULL" for a meter reading of 3 on the top scale. Watch the scope or other power output device (VTVM on output or VOM on Antenna). Adjust "TUNE" control. See that maximum power output comes at the point of minimum plate current on the GALAXY meter, and that meter reading goes up on either side of resonance. If this is not the case, adjust the neutralizing capacitor in small steps until this condition does exist. **DANGER! HIGH VOLTAGE! TURN OFF THE B+ BEFORE ADJUSTING THE NEUTRALIZING CAPACITOR.**
26. Adjust "NULL" for minimum carrier output. Insert 1000 cycle tone into the microphone jack. Ring is audio, sleeve is ground. Level needed is approximately .02 volts RMS. Advance "MIC" gain until meter reads 2-1/2 on the top scale. The scope pattern should be adjusted for a two inch height. Ripple should be less than 1/10 inch on either sideband.
27. Turn "MIC" gain counterclockwise to "OFF". Adjust "NULL" for a reading of 2 on the top scale of the GALAXY meter. Advance "MIC" gain until a fully-modulated two-tone test is seen on the screen. The meter should rise to about 2-1/2. The tops of the scope pattern should reach the same height as with full carrier and no audio inserted, indicating the same PEP output on two-tone as on carrier ("single-tone"). The cross-overs should be clean and sharp.
28. Checking the VX-1 VOX accessory. **DANGER! HIGH VOLTAGE! TURN OFF B+!** Remove octal plug from the left rear of the GALAXY, and

plug the VX-1 into the octal socket. Allow one minute warm up. Plug microphone into GALAXY. Set VX-1 "VOX GAIN" to "PTT". Press button on microphone. If the push-to-talk circuit works, all control circuits in the VX-1 are operating. Advance the "ANTI-VOX" fully clockwise, "HOLD-TIME" about 1/2 scale. While close-talking the mike in a normal voice, advance the "VOX GAIN" until the unit operates reliably.

If the above sections make it sound that a good knowledge of radio in general and transceivers and test equipment in particular is necessary to properly align the GALAXY 30, rest assured that this is exactly the case. A ham who has the knowledge and equipment will find it a very straightforward job, but if you are not sure of what you are doing, get help from someone who knows! The GALAXY 300's performance depends on proper alignment, as does every similarly complex piece of gear! The factory is always available by letter, or during business hours by telephone, to answer any questions you may have. You will find WRL most cooperative.

*Galaxy 300*  
SCHEMATIC Figure M

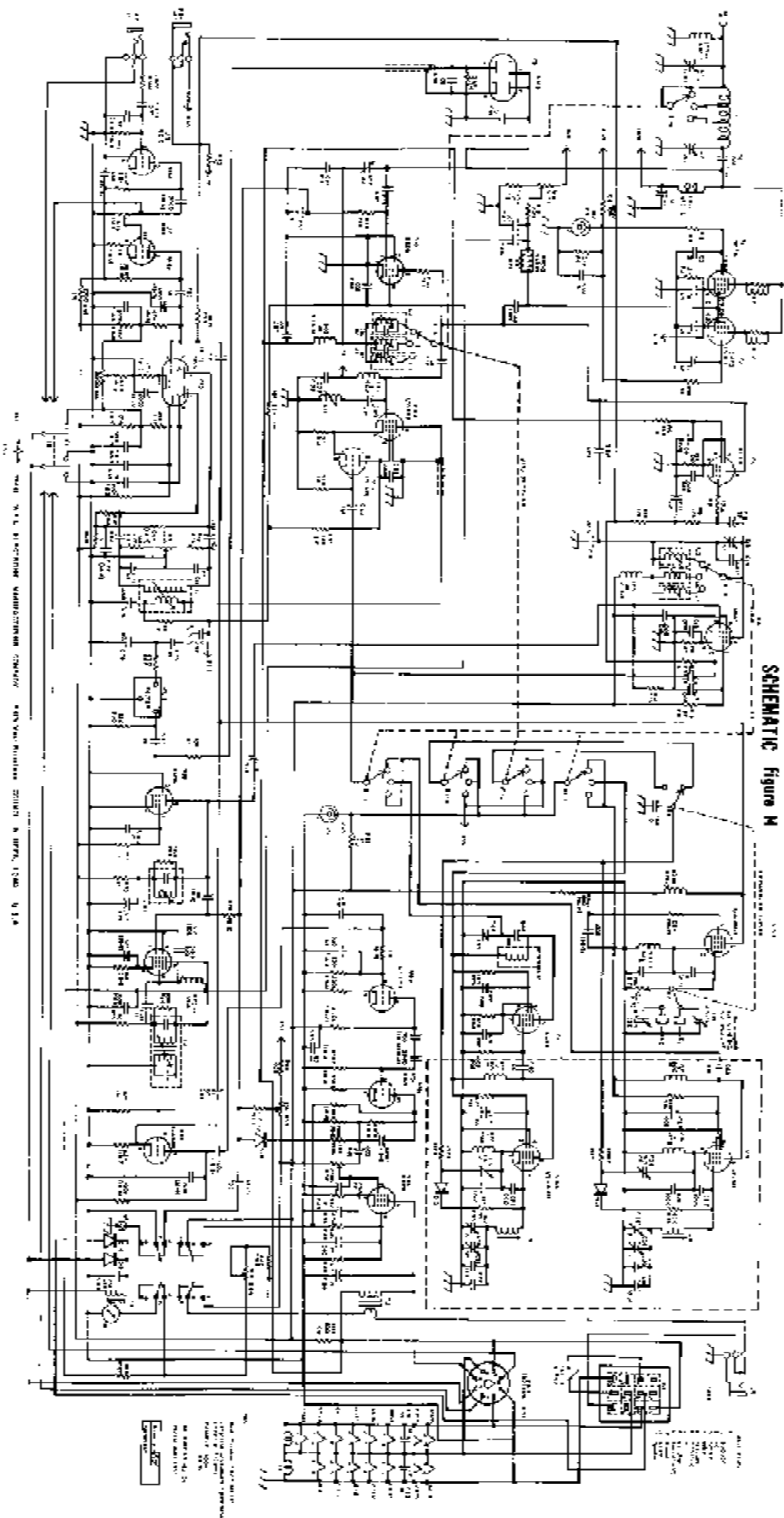

ALL VACUUM TUBE SOCKETING AND WIRING TO BE DONE IN ACCORDANCE WITH THE GALAXY 300 SERVICE MANUAL, PART 1, 2, 3, 4, 5, 6, 7, 8, 9, 10, 11, 12, 13, 14, 15, 16, 17, 18, 19, 20, 21, 22, 23, 24, 25, 26, 27, 28, 29, 30, 31, 32, 33, 34, 35, 36, 37, 38, 39, 40, 41, 42, 43, 44, 45, 46, 47, 48, 49, 50, 51, 52, 53, 54, 55, 56, 57, 58, 59, 60, 61, 62, 63, 64, 65, 66, 67, 68, 69, 70, 71, 72, 73, 74, 75, 76, 77, 78, 79, 80, 81, 82, 83, 84, 85, 86, 87, 88, 89, 90, 91, 92, 93, 94, 95, 96, 97, 98, 99, 100.





WORLD RADIO'S VOICE OPERATED RELAY MODEL VX-1

1. DESCRIPTION AND PURPOSE:

This unit is a plug-in VOX for use with the World Radio Galaxy 300 Single Sideband Transceiver to convert from push-to-talk operation to voice controlled operation. It is constructed on a  $3\frac{1}{2}$  x  $2\frac{7}{8}$  x  $2\frac{1}{2}$  inch chassis. The VX-1 uses one 6U8A and one 6BJ8 tube, a sensitive relay and three controls. It plugs in, internally, on the Galaxy 300 chassis and becomes an integral part of the transceiver.

2. THEORY OF OPERATION:

The sensitive relay replaces the action of the push-to-talk switch. The relay is operated by voice signal from the microphone as follows: The microphone signal is amplified by 1/3 of the 6D10 in the transceiver. This amplified signal feeds the pentode section of the 6U8A; then to the triode section of the 6BJ8. Next, this amplified voice signal feeds a diode of the 6BJ8 which develops keying bias for the 6U8A triode relay keying tube. A gain control setting the "operate sensitivity" is in the grid circuit of the 6U8A pentode and is labeled "VOX GAIN." The "HOLD TIME" potentiometer is in the cathode circuit of the diode.

The anti-trip circuit picks up receiver audio from the plate circuit of the 6AQ5A in the transceiver and feeds it, via the "ANTI-VOX" potentiometer, to the second diode of the 6BJ8, which supplies a delay bias to the first (or keying) diode. Special roll-off circuitry is included to reduce accidental operation from extraneous noises.

3. INSTALLATION IN THE GALAXY 300 TRANSCEIVER:

TURN OFF POWER SUPPLY! DISCONNECT POWER SUPPLY FROM TRANSCEIVER! THIS IS IMPORTANT!

Open cabinet lid. Remove octal plug at left rear of chassis and plug VX-1 into this socket.

4. ADJUSTMENT:

Turn "VOX GAIN" control counter-clockwise until switch clicks. Turn "HOLD TIME" control all the way counter-clockwise. Turn "ANTI-VOX" control all the way clockwise.

Reconnect power supply to transceiver and set up for normal push-to-talk operation on any band.

Turn "VOX GAIN" control clockwise, while speaking into the microphone in a normal voice, until VX-1 operates and the transceiver goes to transmit. Adjust "VOX GAIN" and "HOLD TIME" to suit your own operating needs. It may be necessary to decrease the setting of the "ANTI-VOX" control in some instances.

Close cabinet lid. No further adjustment should be necessary unless microphone or operator are changed.



